

Smoothflow Pump

XPL

Direct-Driven Type

Metered Supply

Trace Amount Supply

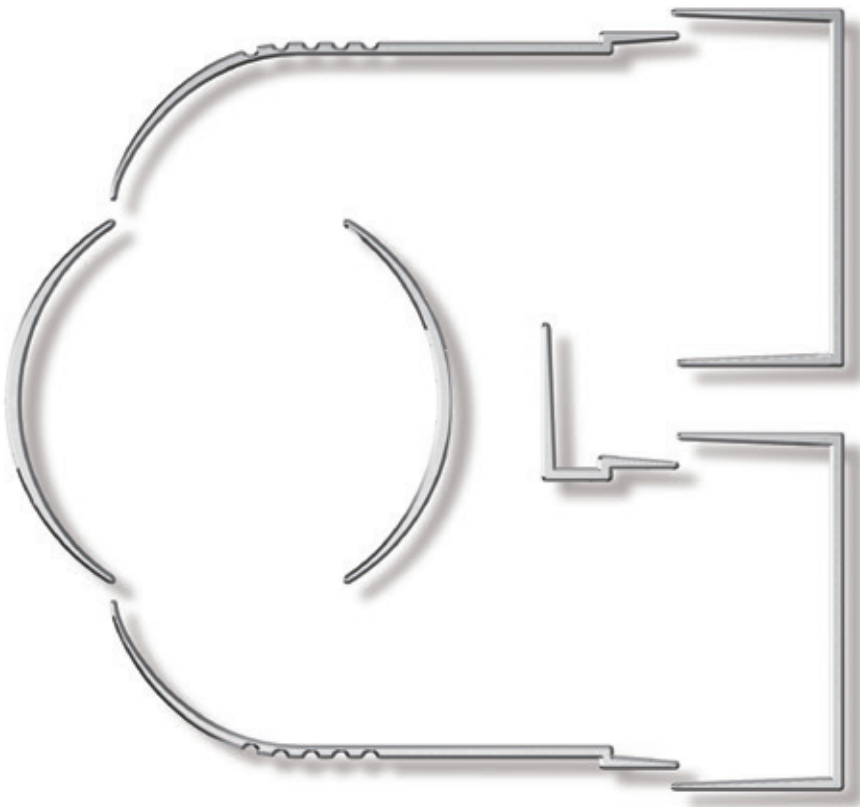

Smart & Compact

Introducing “Smart Pumps,” precision pump technology condensed into a compact body.

The XPL Series embodies the combination of product development and improvement ideas from more than half a century in pursuit of precision pump technology with an always-attentive ear for customer requests and concerns.

In addition to basic performance improvements such as accuracy and capabilities, these “Smart Pumps” offer every element necessary for a pump—from usability and maintainability to cost performance—packed into a compact body.

The XPL Series of pumps was designed to solve all the unavoidable and unanswerable problems that came with conventional pumps.







Improving the Quality of High-Precision Chemical Transferring

Pulsations have been eliminated at the pump. For precise chemical transferring at a continuous flow, the XPL Series makes it possible to maintain a stable chemical concentration.

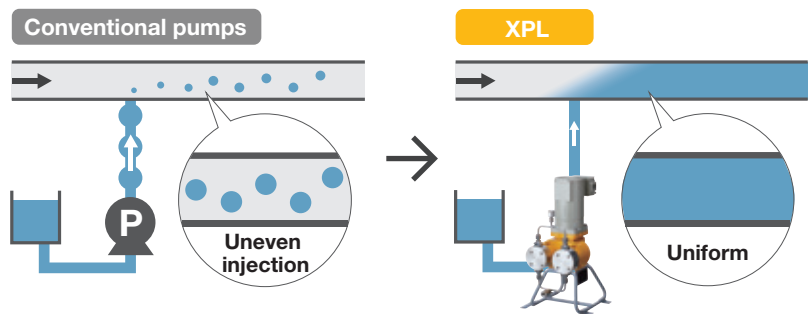

Air Chamber Response Lag

In the air chamber, "discharge delay" time lags occur between when pumping is started and when the actual flow rate becomes stabilized at the set flow rate. When pumping is stopped, "dripping" occurs when liquid continues to flow in the chamber. Also, when the pressure is varied, the flow rate remains unstable until the air pressure in the chamber stabilizes, leading to a reduction in quality. With the XPL Series, the actual flow rate is equal to the set flow rate with no time lag. The XPL Series' ability to provide a continuous stable supply for chemical transferring can contribute to maintaining product quality.

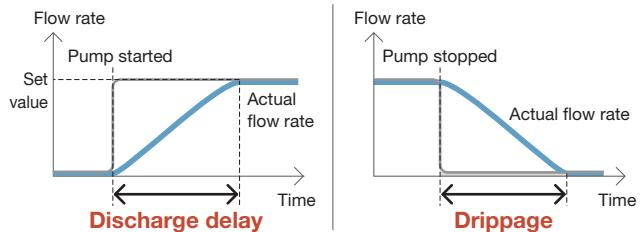

No Intrusion of Air or Leakage

The completely sealed structure prevents changes in liquid quality caused by air intrusion while protecting factory conditions by preventing leaks.

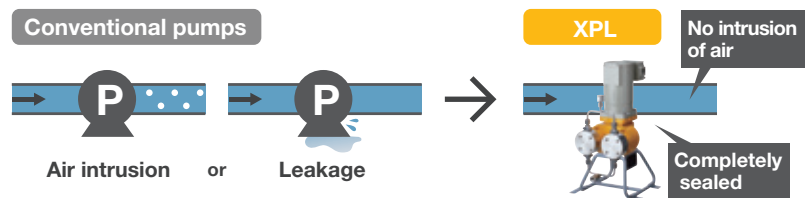

Wear-Resistant with No Sliding Parts

The lack of sliding parts in liquid-end components means you never have to worry about damaging slurry or about malfunctions and contamination due to pump wear even when transferring slurry.

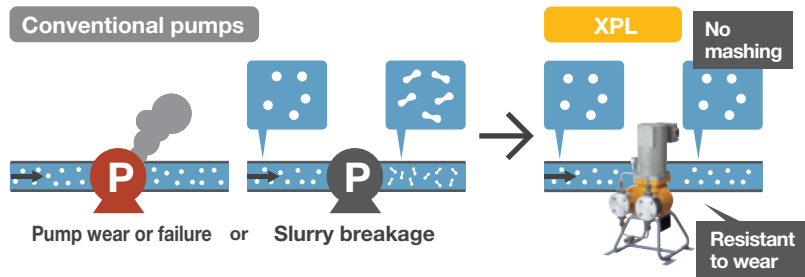

Improving the Quality of Coating Processes

The XPL Series ensures high-quality coating by preventing coating unevenness and horizontal steps caused by pulsation as well as empty spots caused by foaming or air intrusion during feeding.

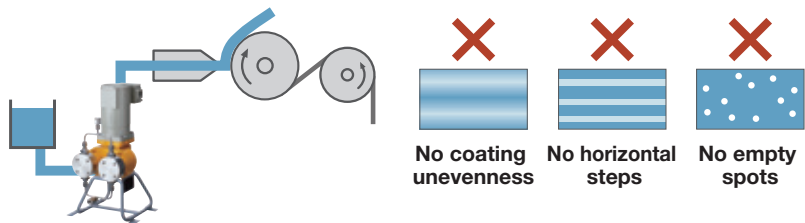

For Those Looking For Better Control...

With reciprocating pumps, slight mechanical vibrations occur due to its characteristics during feeding. Refiners control the minute fluctuations caused by those vibrations in order to establish a stable chemical supply with higher accuracy.



Installation

Simply attach to the discharge side piping

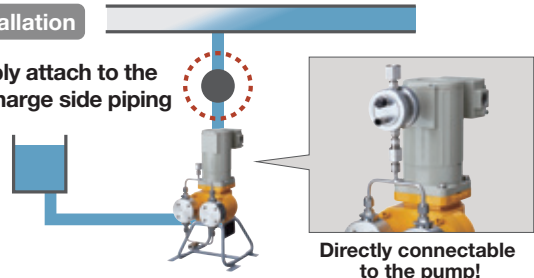



Smart Equipment Design for Reduced Installation Space and Costs

2-liquid mixing systems

By combining the mixing and dilution processes in-line, auxiliary equipment such as mixing tanks, agitators, and transfer pumps become unnecessary. Systems can be designed to be compact and simple.

Conventional pumps

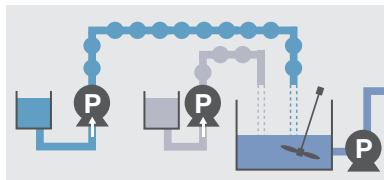

XPL

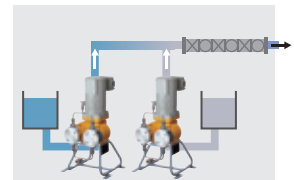

Wide-range controlling

Using just the inverter and controller, wide-ranging 100:1 control is possible.

Conventional pumps

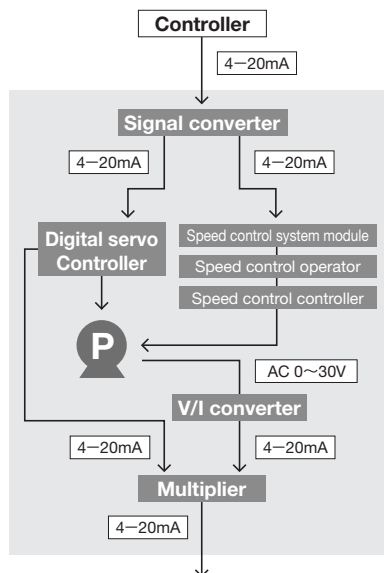

XPL

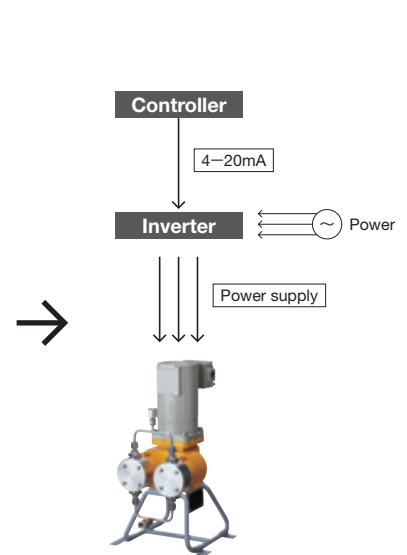



Automatic Control System for Reduced Management Work

The ability to measure flow using the flow meter means users can manage the feed amount in real-time as well as instantly change the flow rate using the inverter. Automatic control systems can be built easily by combining these and other measuring instruments.

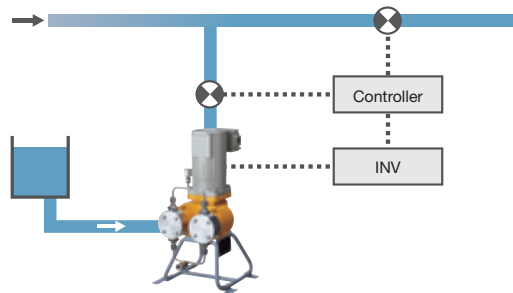

“Smart” Design for Incorporating in Equipment

Compared with conventional products of similar specifications, the XPL Series offers 20% less volume and weighs 30% less. In addition, the pump can be used in equipment even without a base, making incorporation that much more compact.

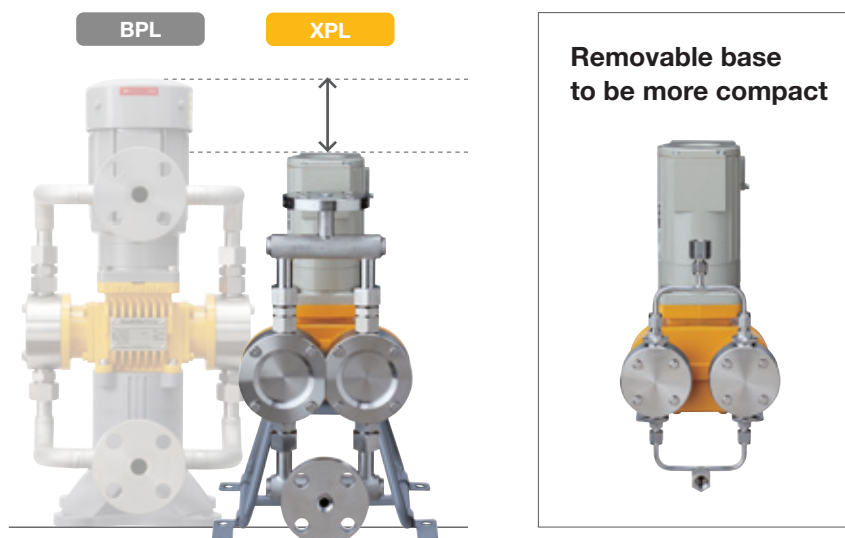



Easy Disassembly and Maintenance

Disassembly without removing piping

Liquid-end parts can be disassembled even while the piping is connected, helping to minimize work time.

Simple maintenance of liquid-end parts

Thanks to a forward layout design, the two pump heads are positioned toward the front. This makes it possible to perform maintenance even with limited space.

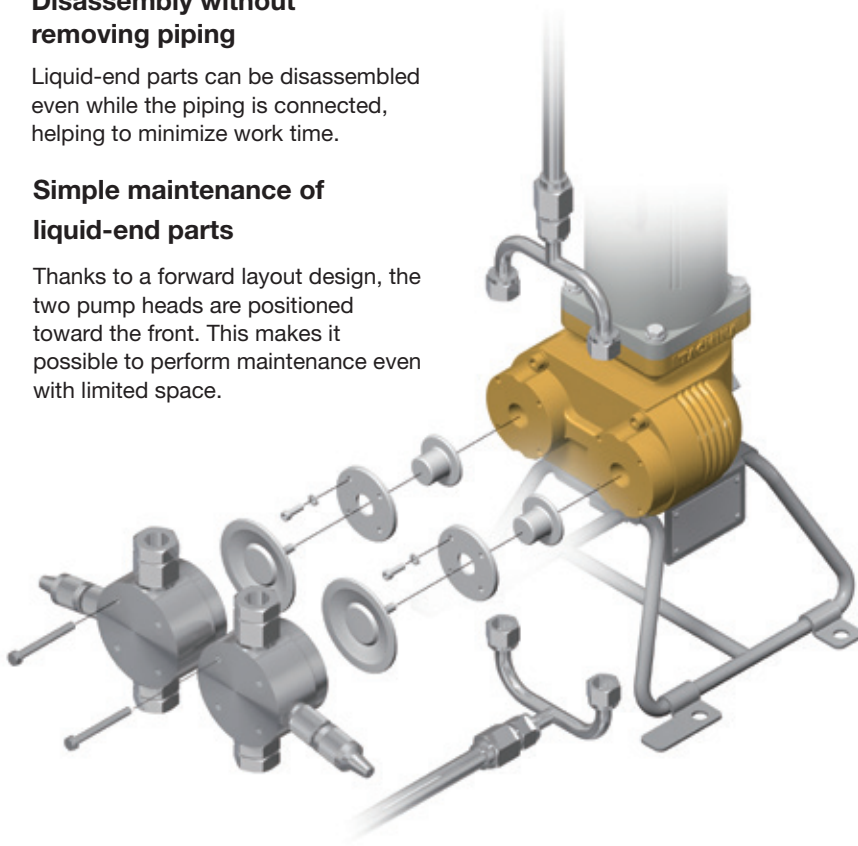

Electroless nickel plating for compatibility with organic solvents

The XPL Series features electroless nickel plating, making it usable for transferring organic solvent-based chemicals. This also makes maintaining a clean process simpler.



Support for sanitary specifications

Sanitary types are also available upon request for food, medicine, fine chemicals, and other customer needs.



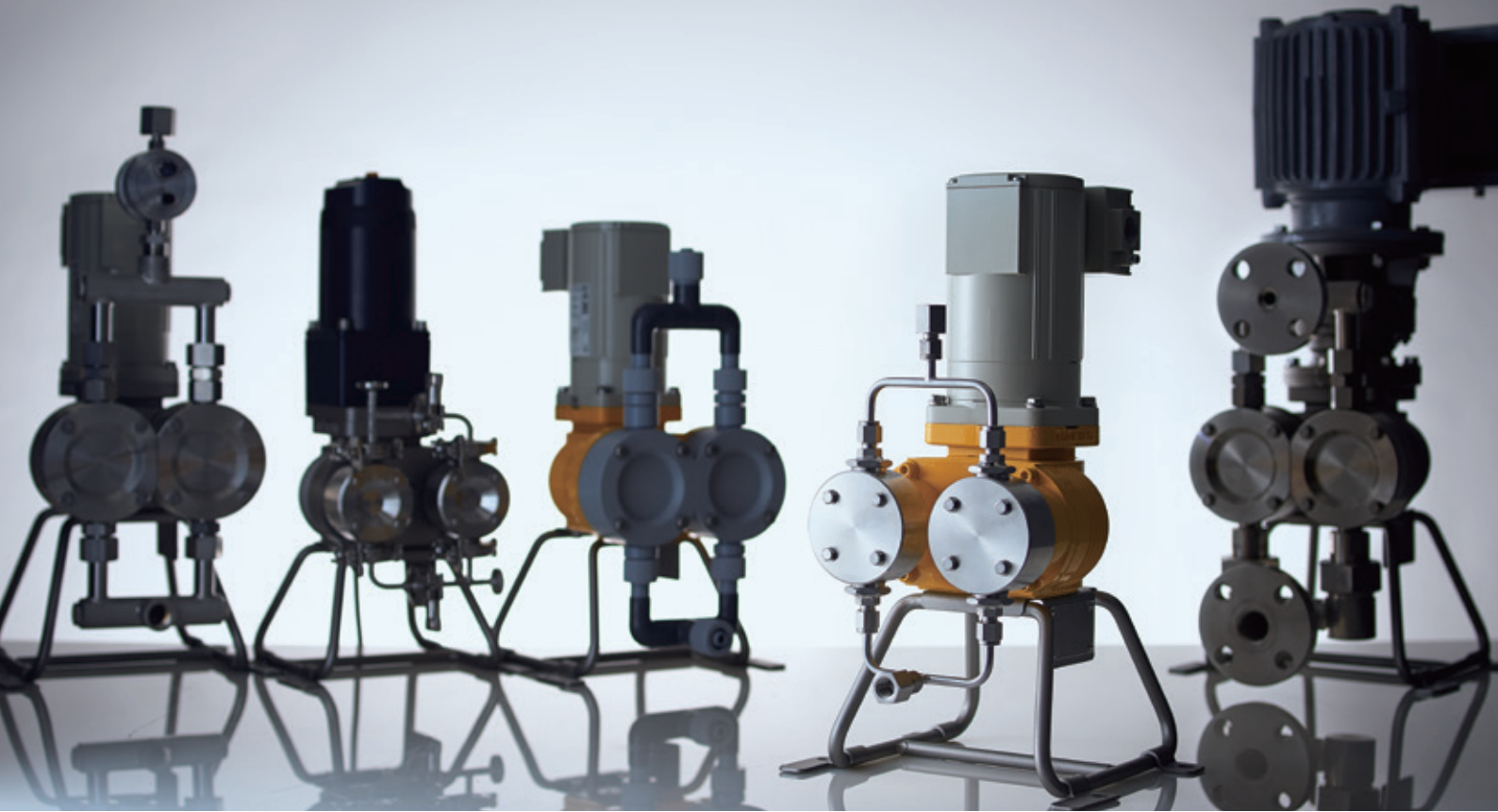

Easy to Customize to Suit Applications and Requests

Specifications are flexible and can be changed to match the characteristics of transfer liquids, applications, and installation site circumstances.

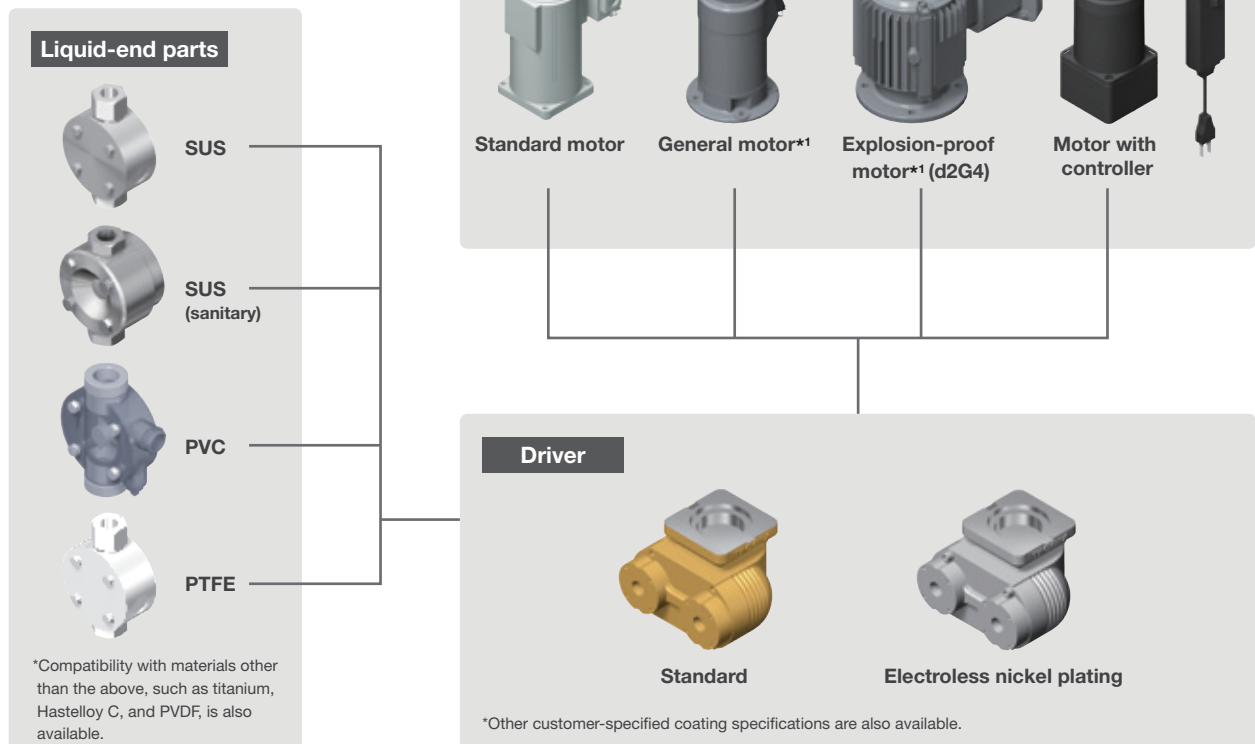

*1 Dedicated adapter required separately.

*Liquid-end parts are examples. Shapes may differ depending on the model.

Applications

General chemical injection

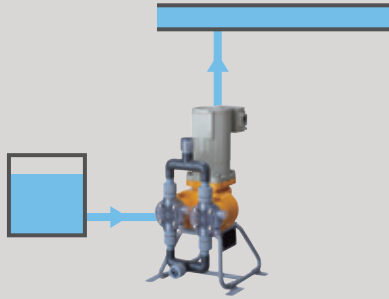

Laboratory-scale transferring of trace amounts

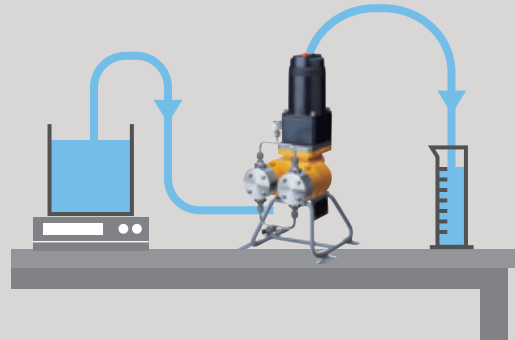

Dispersion

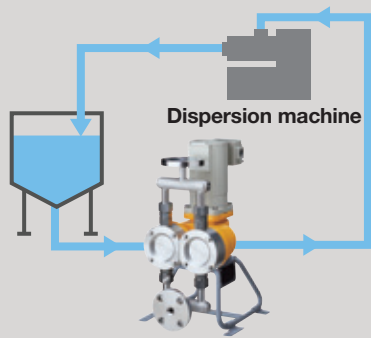

Mixing/Blending

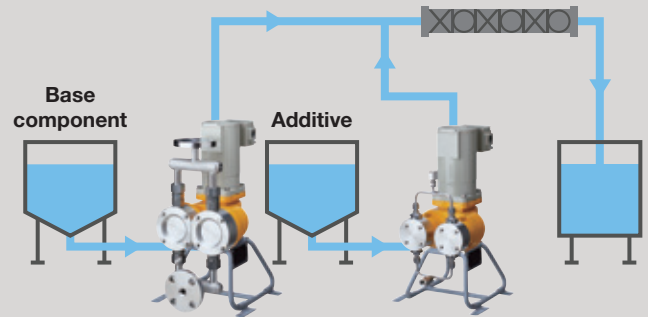

Filtration

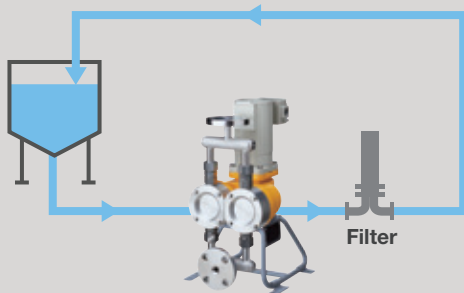

Thin film coating

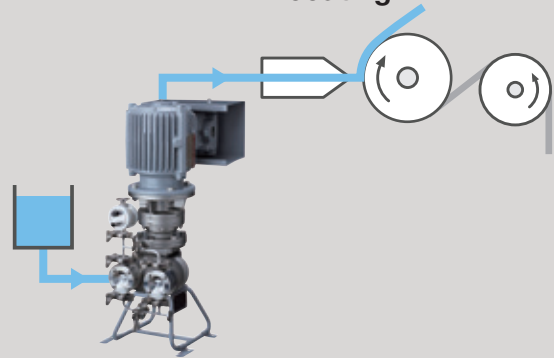

Spray-drying

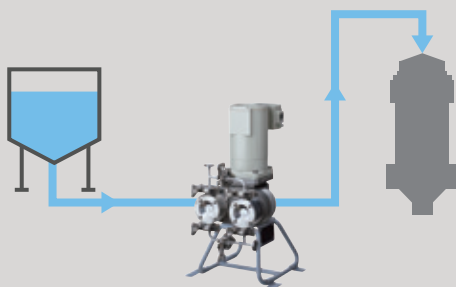

Coating

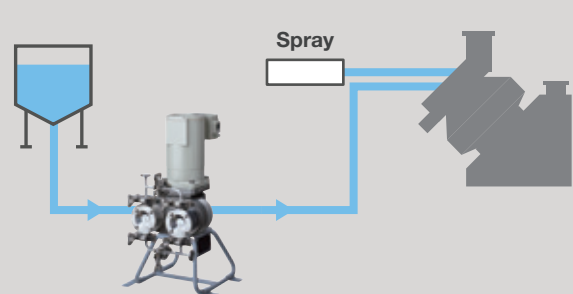

Model Codes



1 Series name
XPL : Standard
XPLS : Sanitary*1

2 Model
001
003

3 Liquid-end material
STST
VTCE
VTCF

4 Connection type
M : Female screw
F : Flange

5 Valve seat structure
W : Standard
V : High-viscosity type

6 General specification
S : Standard
X : Special

01	STST	M : Female screw	W : Standard
03	VTCE	M : Female screw	W : Standard
1	VTCF	F : Flange	H : Hose
	VT6E	F : Flange	V : High-viscosity type
	VT6F	H : Hose	
3	STST	M : Female screw	W : Standard
	VTCE	F : Flange	
	VTCF		

*1 With sanitary specifications, the liquid-end material **3** will be "STST," and the connection type **4** will be "C: Clamp."

Specifications

		001	003	01	03	1	3
Max. discharge volume*1	L/min	0.009*3 (0.01)	0.025 (0.028)	0.1*4	0.3	1	3
	L/h	0.54*3 (0.6)	1.5 (1.68)	6*4	18	60	180
	US G/h	0.14 (0.15)	0.39 (0.44)	1.58	4.75	15.84	47.52
Max. discharge pressure	MPa	1.5		1.0		0.5	
	bar	15		10		5	
	psi	217.5		145		72.5	
Stroke speed	strokes/min	7 to 61					40 to 160
Stroke length	mm	1	2	6			
Frequency setting range	Hz	6 to 60					15 to 60*8
Operating temperature	Liquid transfer temperature	SUS type: 0 to 60 / PVC type: 0 to 40 (no freezing)					
	Ambient temperature	0 to 40					
Max. transferrable viscosity	Standard	50 or less					
	High viscosity	2000 or less					
Connection	Hose	Discharge side	—		φ6×φ11*5	φ12×φ18*6	—
		Suction side	—		φ12×φ18	φ12×φ18*6	—
	Flange	Discharge side	—		JIS10K15A	JIS10K15A*7	JIS10K15A
		Suction side	—		JIS10K15A	JIS10K15A*7	JIS10K20A
	Screw	Discharge side	Rc 1/4		Rc 3/8		Rc 1/2
		Suction side	Rc 1/4		Rc 3/8		Rc 1/2
Motor	Model	Fully-closed self-cooling outdoor type					
	Power supply / Frequency	3-phase 200 V (50Hz) / 200/220V (60Hz)*9					
	Output / No. of poles	0.1kW/4P					
	Insulation class / Cable conduit connection diameter	E / PF 1/2					
	Rated current / Max. start current	200V/50Hz	0.69A/2.1A				
200V/60Hz		0.60A/1.9A					
220V/60Hz		0.60A/2.1A					
Weight*2	SUS type	12.3			16.4		17.4
	PVC type	10.3			10.4		12.2

* Max. discharge volumes are for room-temperature water.

*1 Values in parentheses are for 1.0MPa. *2 For standard screw connection types. *3 VTCE / VTCF: 0.008L/min (0.48L/h) *4 High-viscosity type: 0.09L/min (5.4L/h)

*5 High-viscosity type: φ12×φ18 *6 High-viscosity type: φ19×φ26 *7 High-viscosity type: JIS10K20A *8 Settings of 6 to 60Hz are possible with discharge pressures of 0.3MPa or less.

*9 400V (50Hz) / 400×440V (60Hz) motors are also available.

Materials

	STST	VTCE	VTCF	VT6E	VT6F
Pump head	SUS304	PVC			
Diaphragm	PTFE				
Check ball	SUS304	Ceramic		SUS316	
Fittings	SUS304	PVC			
O-ring	PTFE*1	EPDM	Fluoro rubber	EPDM	Fluoro rubber
Ball stopper	—	PVC		—	—
Valve seat	—	EPDM*4	Fluoro rubber*4	—	—
Valve stopper	PTFE*2	PE*2		PE*5	
Ball guide	SUS316*3	PVC*3		PVC*2	
Compressed coil spring	—	—	—	SUS304WPB	

* Production using other materials (PTFE, PVDF, titanium, Hastelloy C, etc.) is also possible. Contact TACMINA for details.

*1 XPL-3: PTFE, PFA/silicone rubber

*2 Included with XPL-1/3.

*3 Included with XPL-3.

*4 Included with XPL-001/003/01/03.

*5 Included with XPL-01/03.

External Dimensions

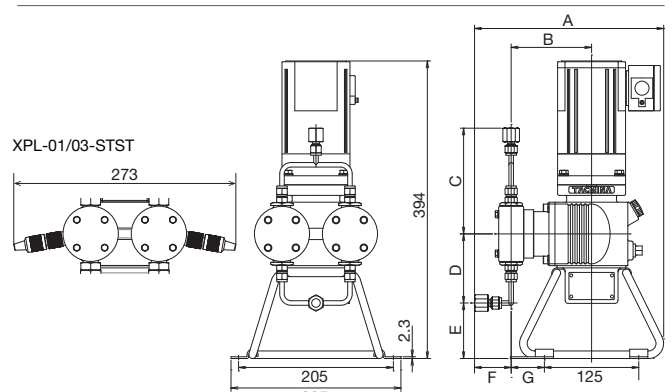

	A	B	C	D	E	F	G
001	250.5	106.5	140	91.5	73.5	48.5	44
003	250.5	106.5	140	91.5	73.5	48.5	44
01	263	107.5	175	108	57	60	45
03	267	107.5	175	108	57	60	49
1	238	114.5	171	125	40	28	52
3	245	114.5	171	121	44	35	52

*The drawing shows XPL-001-STST-MWS. Shapes may differ depending on the model.
*Dimensions are for STST types with female screw connections. Contact us for other models or connections.

Recommended Piping Example

In order to make full use of metering pump performance (metering, discharge accuracy, etc.), installation of the correct piping design and auxiliary devices is required. Appropriate piping can also lead to prevention of piping and pump trouble as well as accidents, ensuring safety and security of the production line. The recommended piping for the pump model will assure full utilization of the metering pump's capabilities.

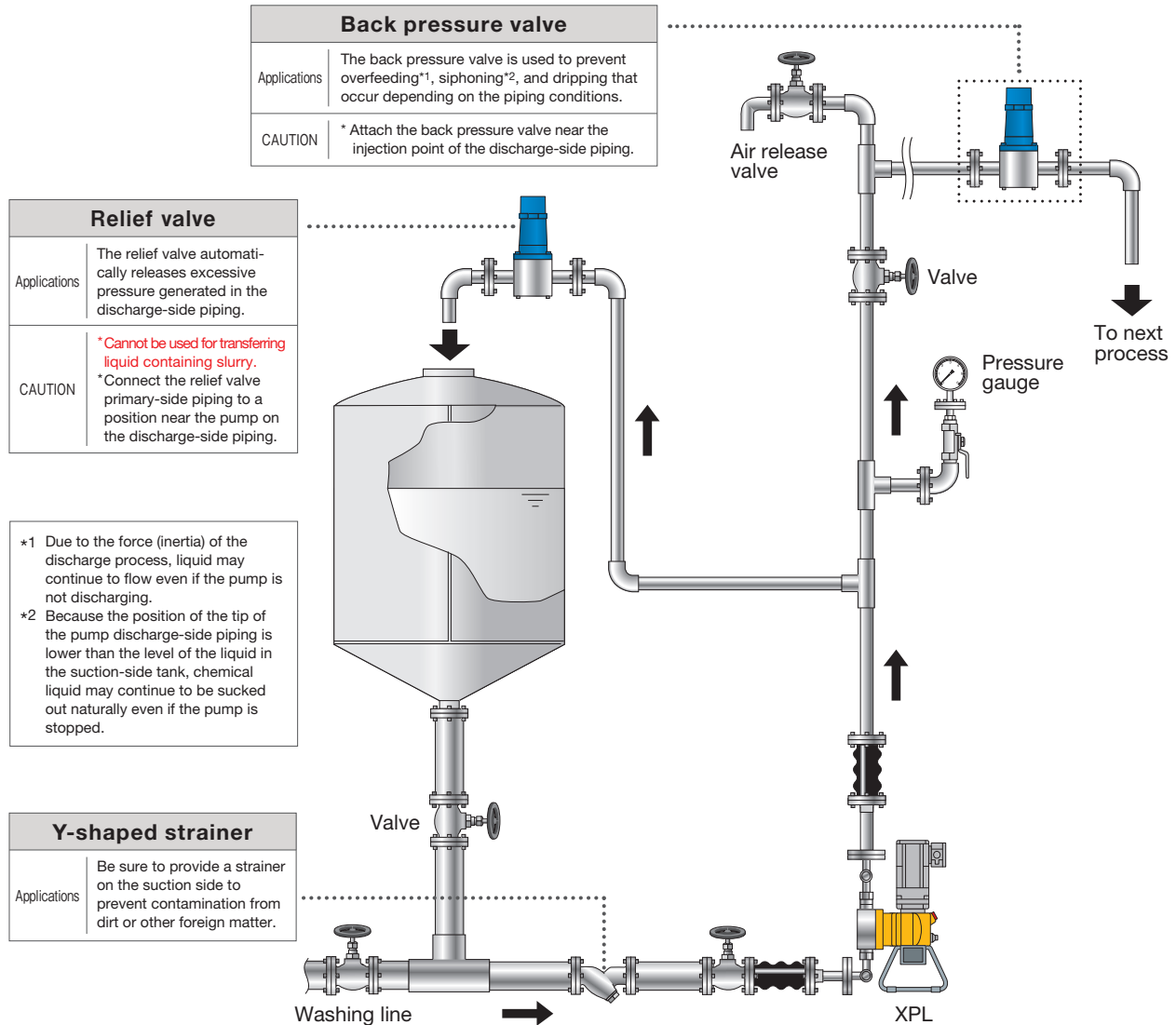

Notes on Metering Pump Piping

- | | | | | |
|--|---|---|--|--|
| <p>Point 1</p> <p>If necessary, provide exhaust piping on the suction side. (For example, when dealing with liquids that generate gas or volatile liquids such as sodium hypochlorite.)</p> | <p>Point 2</p> <p>With long piping, there is a risk of increased piping resistance, abnormal pressure generation, and diaphragm or eccentric shaft damage.</p> | <p>Point 3</p> <p>*Be sure to install the relief valve near the pump on the discharge-side piping. Doing so will prevent pump malfunctions due to abnormal pressure.</p> | <p>Point 4</p> <p>For discharge-side and suction-side piping, as well as the relief valve and back pressure valve, select piping that is larger than the pump diameter in order to prevent piping problems.</p> | <p>Point 5</p> <p>Design the suction-side pump piping so that it is short and simple.</p> |
|--|---|---|--|--|

*The above diagram is only an example. For details, contact your TACMINA representative.

*A hydraulic double-diaphragm pump is appropriate for high-precision transferring and injection of liquid that contains slurry or high-viscosity liquids. Contact your TACMINA representative for detailed piping designs.

*For maintenance and inspection purposes, install a valve before and after each device.

Product designs and specifications are subject to change without notice for product improvement.

TACMINA CORPORATION

Head Office:

2-2-14 Awajimachi, Chuo-ku, Osaka 541-0047 Japan
 Tel.+81(0)6-6208-3974 Fax.+81(0)6-6208-3978
 URL <http://www.tacmina.com>
 E-mail trade@tacmina.com

EC-062 (3) --
 2017/5/S--



JQA-A-1274
 JQA-EM0337 Production Department