

TACMINA

*Smoothflow* Pump

**APL**

Direct-driven type

Metered transfer

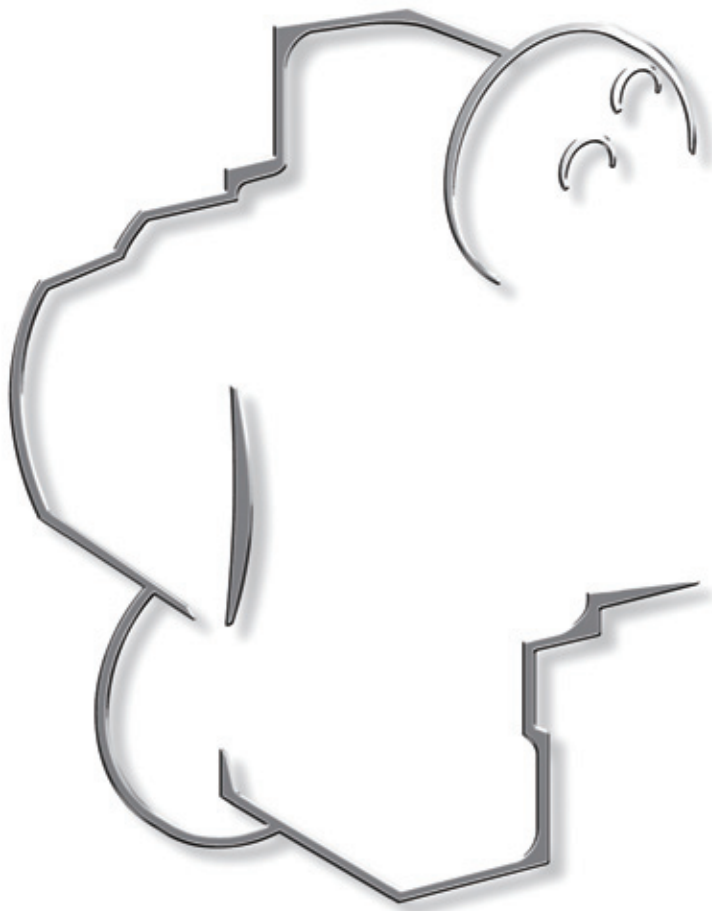

# Solving Trouble and Dissatisfaction of Transfer Pumps in a Single Stroke

With rotary volumetric pumps and other conventional pumps, there has always been the danger of liquid leakage and intrusion of foreign matter. What's more, disassembly and maintenance has always been a major source of troublesome tasks.

The TACMINA APL Series of universal pumps provides a total solution for all of your pump-related troubles.

As well as demonstrating excellent discharge accuracy and resistance to wear, the APL Series drastically reduces labor during maintenance and helps improve the reliability of processes.



## Major Trouble and Dissatisfaction with Transfer Pumps

### Current Problems

---

- No 1** ..... **Liquid leakage (and its risk)**
- No2 ..... Worn parts
- No3 ..... Fluctuating flow rate
- No4 ..... Intrusion of foreign matter
- No5 ..... Compatibility with slurry liquid
- No6 ..... Maintenance (including cost)

### Important Points in Pump Selection

---

- No 1** ..... **Performance (specifications, capabilities)**
- No2 ..... Track record
- No3 ..... Maintainability
- No4 ..... Cost
- No5 ..... Accuracy

### Properties of Transferring Liquid

---

- No 1** ..... **High viscosity**
- No2 ..... Slurry liquids
- No3 ..... Organic solvents
- No4 ..... Expensive liquids
- No5 ..... Highly corrosive liquids

### Preconception of Diaphragm Pumps

---

- No 1** ..... **Generate pulsation**
- No2 ..... Low flow rate
- No3 ..... Unable to transfer slurry liquids
- No4 ..... Poor maintainability
- No5 ..... Unable to transfer high-viscosity liquids

\* This ranking is based on the results of a product satisfaction survey conducted among displacement pump users by TACMINA in November and December 2004.



## For Those Who Want Total Control in Liquid Flow

Smoothflow — the ideal method of liquid transfer. This innovative method not only meets your liquid transfer needs, but provides optimal solutions to Man, liquids and the environment as well.

TACMINA's Smoothflow technology, based on unique know-how cultivated over 50 years, delivers you ultimate performance and provides complete satisfaction.

Ideal Method of Liquid Transfer

*Smoothflow*

• Constant & Stable Flow

• Eco-Friendly

• Economical

• Gentle on Liquids



### APL Series

Max. discharge volume : 47 L/min  
 Max. discharge pressure : 0.5 MPa  
 Liquid end material : SUS / PVC / PVDF



### APLS Series (sanitary type)

Max. discharge volume : 47 L/min  
 Max. discharge pressure : 0.5 MPa



### Handy unit type

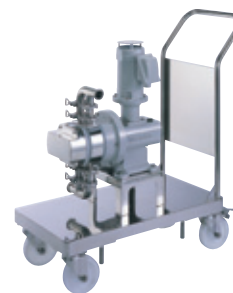

### Trolley type

# The Answer Lies in Its Two Opposite Diaphragms

The two diaphragms act in concert together to gently and reliably transfer liquids as if they are softly caressing them with both hands. This at once solves various problems and improves productivity.

## Pump head

A proprietary mechanism comprising two pump chambers opposite each other simplifies the structure of the pump head. Liquid is transferred at a consistently steady flow rate by the front and rear pump heads repeatedly and alternately discharging liquid. What's more, this highly efficient pump head structure has been designed to be contamination-proof and very easy to clean.

## Motor

As well as motors for inverters and different voltages, TACMINA also provides a selection of special motors, for example, for flame-proof applications.

## Diaphragms

Diaphragms are made of highly durable, corrosion-resistant PTFE. This makes them ideal for transferring slurry liquids.

## Valve Seat and Check Balls

Backflow is prevented by a valve seat with excellent sealing capabilities. Users can also choose from materials and structures to suit the properties of the liquid to be transferred.

## Protective Diaphragm

In the event that the diaphragm breaks down, this protective diaphragm acts to reliably protect the pump body from the transferred liquid.

## Special-formed Eccentric Cam

This TACMINA proprietary developed cam minimizes pulsation to ensure that the total discharge volume of the two pump heads is constantly the same.

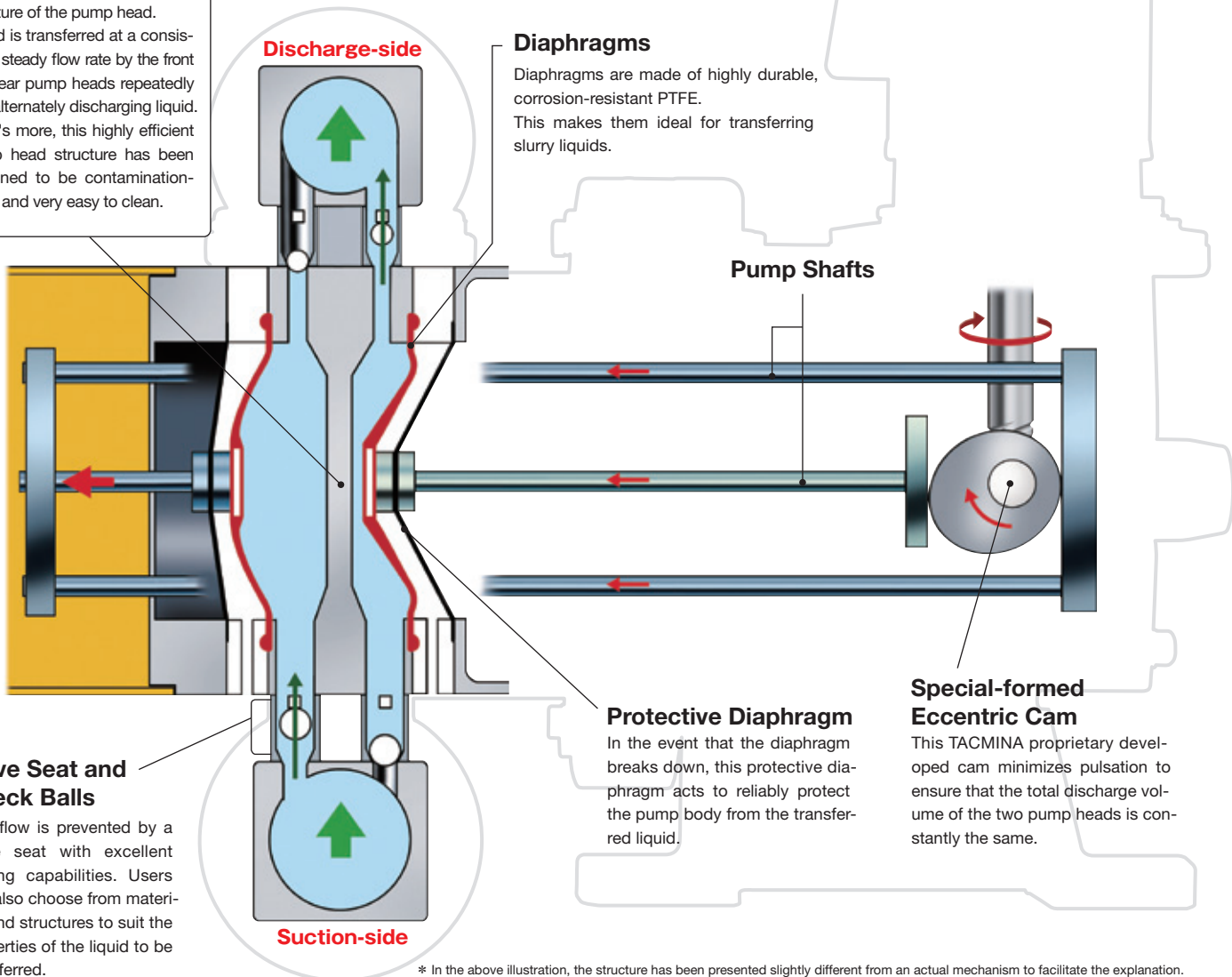

\* In the above illustration, the structure has been presented slightly different from an actual mechanism to facilitate the explanation.

## How pulseless transfer works

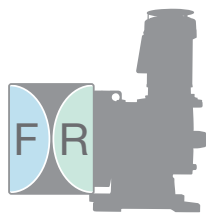
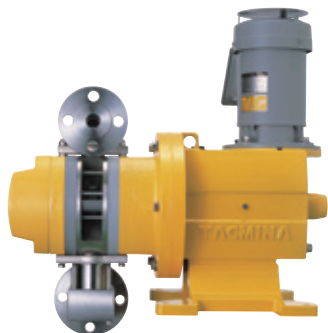

- Suction/discharge waveform on the front side (F)
- Suction/discharge waveform on the rear side (R)
- Total discharge volume on the front and rear sides

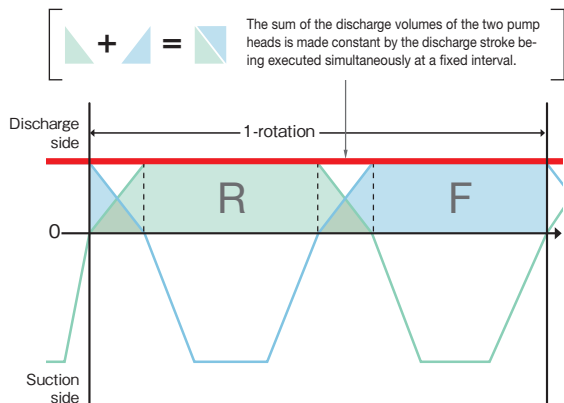

## High-viscosity liquids

Up till now, the transfer of high-viscosity liquids has been generally regarded as difficult. However, thanks to a special pump head structure designed to minimize resistance and contamination, Smoothflow pump can transfer high-viscosity liquids such as polymer coagulants without any problem.

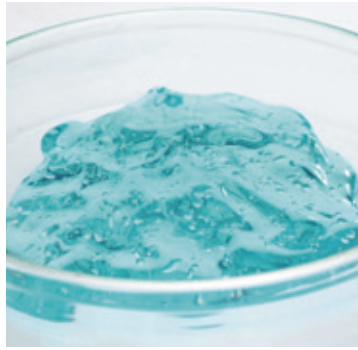

### Examples

- Resin raw materials
- Grease/oil
- Adhesives
- Liquid polymer coagulants ... etc.

Polymer coagulants (non-Newtonian liquid): APL-10

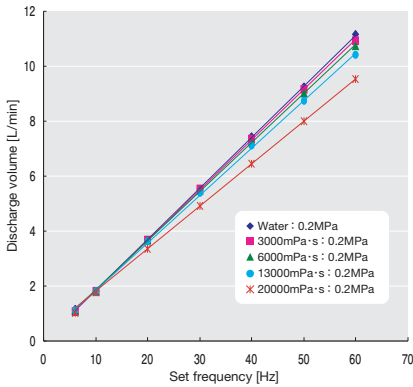

Silicon oil (Newtonian liquid): APL-10

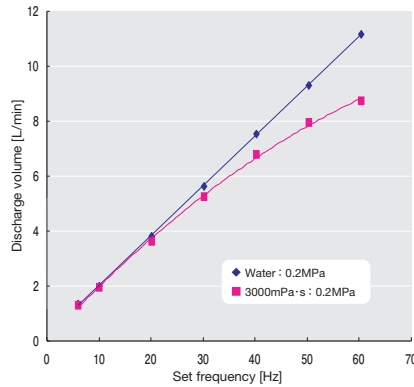

Mayonnaise (non-Newtonian liquid): APLS-10

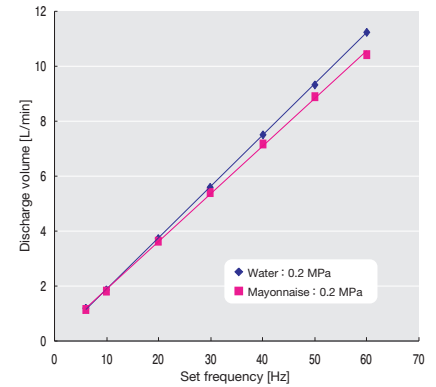

## Slurry liquids

As Smoothflow pumps have no sliding or mating parts, there is no risk of slurry being crushed and slurry damaging the pump. Also, the diaphragms - the liquid-end parts - are coated with PTFE, a highly durable material. This makes them highly wear-resistant and reduces their replacement frequency.

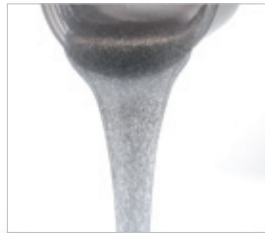

### Examples

- Carbon slurry
- Cells for fuel cell manufacture
- Ceramic slurry
- Silica slurry
- Metallic slurry
- Glaze ... etc.

## Delicate liquids

Even delicate liquids, whose properties are changed by shear or excessive pressure, can be transferred carefully as Smoothflow pump neither has seals nor generates shear.

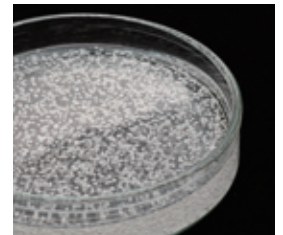

### Examples

- Water-based emulsions
- Fluids containing mica slurry
- UV-hardening resins
- Coating solutions ... etc.

## Low-viscosity liquids

You do not have to worry about transferred liquid leaking to the outside as Smoothflow pump is completely free of mechanical seals. What's more, check valves installed above and below the pump heads reliably suppress backflow. This means that there is no risk of big drops in the flow rate even during transfer of low-viscosity liquids.

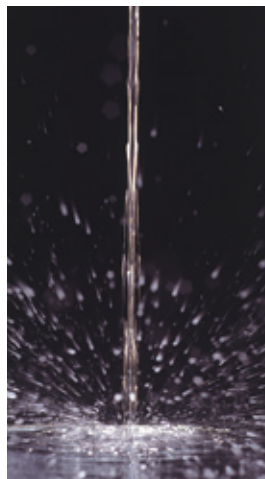

### Examples

- Solvents (IPA, acetone, toluene, MEK, etc.)
- Hydrochloric acid, sulfuric acid
- Water-based paint ... etc.

## Liquids that easily vaporize, harden or crystallize

On Smoothflow pumps, liquid end sections are not exposed to air. This means that you can safely transfer liquids that are likely to vaporize, harden or crystallize immediately through contact with air.

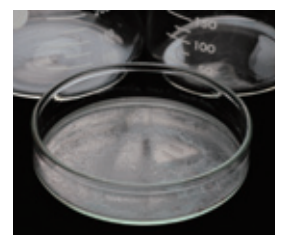

### Examples

- Organic solvents
- Hydrogen peroxide water
- Caustic soda
- Adhesives ... etc.

Transfer capabilities differ according to the transfer conditions. For details, contact your TACMINA dealer.

## Performance

### No leakage

The Smoothflow pump differs from rotary pumps in that it is a completely sealed structure free of mechanical seals. This means that there is no risk of transferred liquids leaking to the outside.

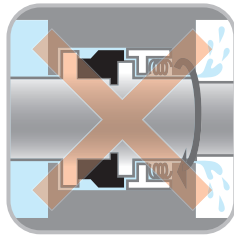

### No entry of foreign matter

Abrasion that creates powder does not arise as Smoothflow pump has no sliding parts at liquid-end sections. This means that you need not worry about powder or foreign matter entering the pump.

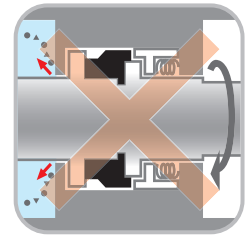

### No damage to liquid

Unlike other types of pumps, Smoothflow pump does not stir or apply excessive pressure locally on liquids. This makes it ideal for transferring delicate liquids whose properties are easily changed by shear, abrasion, pressure, and temperature change.

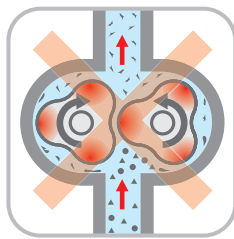

### No pulsation

The APL Series uses a 1-cam, 1-head, 2-diaphragm mechanism, unlike anything else on the market, to suppress pulsation that is a characteristic of diaphragms. Continuous pulseless flow results in excellent metering characteristics and response to flow rate control. What's more, as chemicals can be transferred smoothly, there is little piping resistance. In this respect, the pump excels in the transfer of chemicals over long distances.



### Excellent linearity (little flow rate fluctuation)

Backflow of transferred liquid is reliably suppressed by valve seats with excellent sealing performance. This eliminates big drops in flow rate even if the pressure in the discharge-side piping changes.

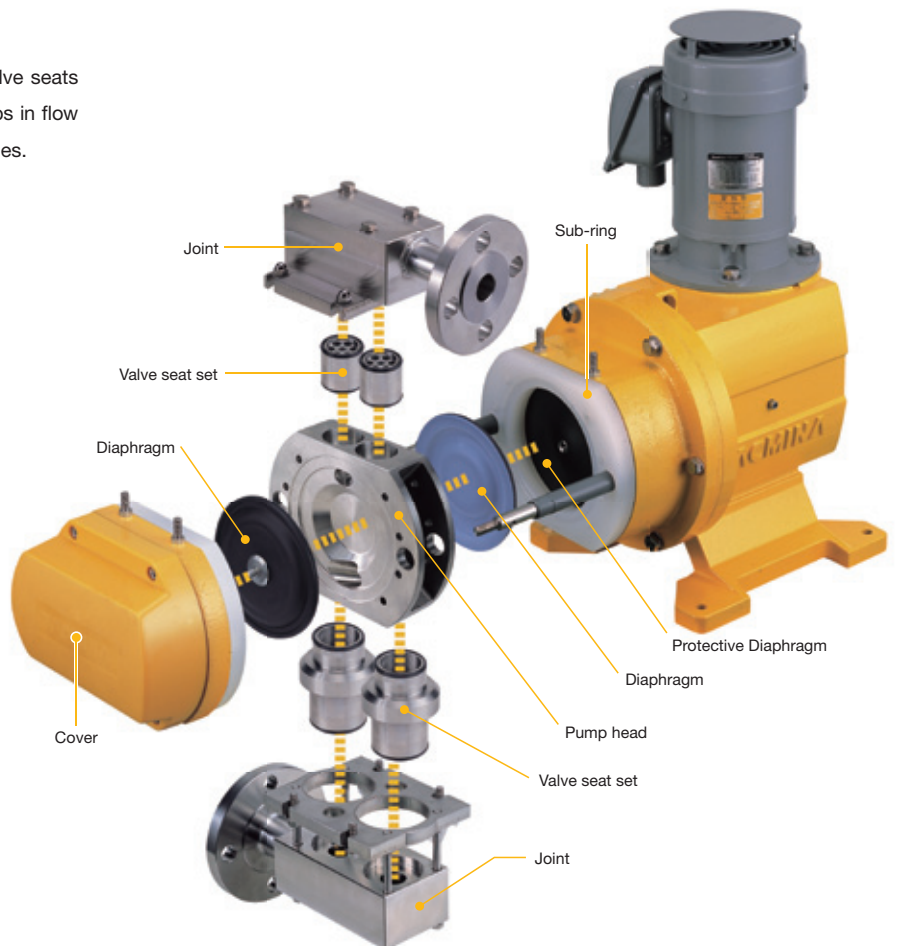
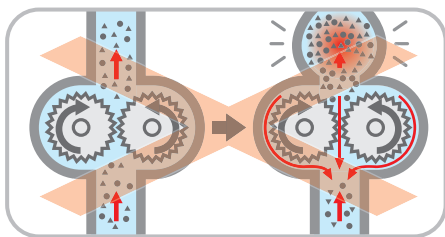

## Durability & Long-Life

### High abrasion resistance

Diaphragms are coated with highly durable PTFE, and need to be replaced once every year or after 4000 hours of operation. This considerably reduces the replacement frequency of parts, that previously had to be frequently replaced, and helps lower running costs.



\* The recommended replacement cycle for consumables is sometimes reduced on some models depending on the properties of the transferred liquid and the operating conditions.

### Dry-running possible

Smoothflow pumps have no sliding parts which used to be required in rotary pumps due to their structure. This means that there is no risk of seals wearing or seizing during idling.

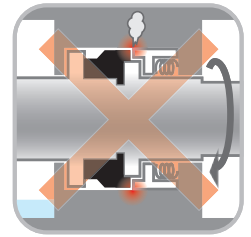

## Maintainability & Installation

### Simple disassembly/assembly

The APL Series is extremely easy to maintain. All you need is two different kinds of wrench, anybody can easily disassemble and assemble liquid-end sections.

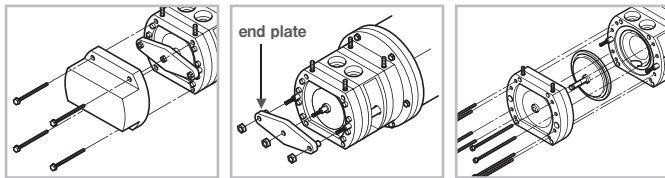

1 Remove the cover.

2 Remove the end plate.

3 Draw out the bolts. Draw out the remaining parts in order.

### Space-saving

Integrating the pump heads into a single head greatly saves installation space. This, in turn, solves a variety of problems - selection of installation site and gaining access space during piping and maintenance.

<Size comparison>

■ APL-50  
■ TACMINA equivalent capability model

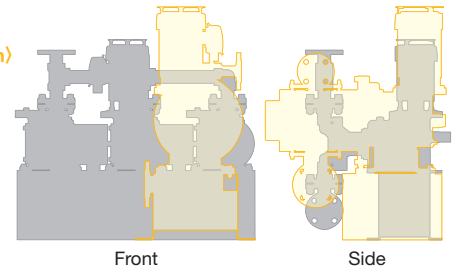

### Few parts, low-cost

The consumables required on the APL Series are only diaphragms, valve seat sets and O-rings that enable low cost investment. Parts can be easily replaced, which means drastic savings in maintenance costs and labor.



Diaphragms (2 pcs)



Valve seat set (2 sets each)

### Easy piping

The joints on both the suction and discharge sides can be changed to face the opposite direction. This allows you to install the pump to conform to the piping conditions, for example, when it is integrated in a system.

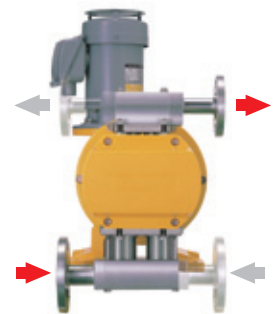

## Applications

### Compatible with a variety of liquids

Pump heads can be provided in a variety of materials such as PVDF in addition to stainless steel and PVC to suit customer specifications. This allows acidic, alkaline and various other chemicals to be transferred.



SUS (stainless steel)

For transferring organic solvents and alkaline liquids



PVC (polyvinyl chloride)

For transferring a wide range of acidic and alkaline chemicals



PVDF (fluoro resin)

For transferring nitric acid, hydrofluoric acid and other strong acidic chemicals

### Transfer both small and large amounts

A line-up of five models - compact thru to large-size model - is available to support a maximum discharge volume range of 5 L/min extending through to 47 L/min.

Choose the pump to suit your capacity and application.

Max. discharge volume 5 to 47L/min / 5models

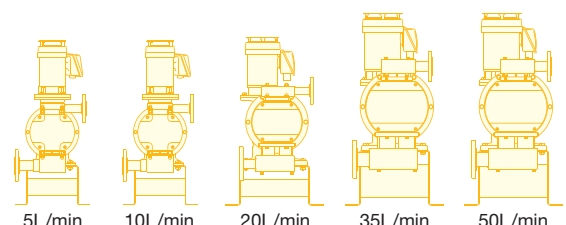

Model Code



**APL - 20 - V T C F - F W S**

1                      2                      3\*1                      4                      5                      6

**1 Series name**  
APL : Pulseless metering transfer pump

**2 Discharge volume**  
5 : 5.5 L/min    35 : 36 L/min  
10 : 10.5 L/min    50 : 47 L/min  
20 : 22 L/min

**3 Liquid end material**  
**a Pump head**  
V : PVC                      6 : SUS14\*3  
S : SCS13\*2                      X : Special

**b Diaphragm**  
T : PTFE  
X : Special

**c Check ball**  
C : Ceramic                      X : Special  
S : SUS304

**d O-ring**  
F : Fluoro rubber                      T : PTFE  
E : EPDM                      X : Special

**4 Connection type**  
F : Flange  
X : Special

**5 Valve structure**  
W : Standard                      X : Special  
V : High-viscosity

**6 General specifications**  
S : Standard  
X : Special

\*1 FTCT is a custom order.    \*2 The APL-5/10 is now made of SUS304.  
\*3 The APL-5/10 is now made of SUS316.  
\* The SCS13 is the cast metal with composition equivalent to that of SUS304 and the SCS14 is the cast metal with composition equivalent to that of SUS316.

Performance Specifications

Specifications		Model	APL-5	APL-10	APL-20	APL-35	APL-50	
Max. discharge volume*1	L/min		5.(5.5)	10.(10.5)	20.(22)	35.(36)	45.(47)	
	L/h		300(330)	600(630)	1200(1320)	2100(2160)	2700(2820)	
	US G/h		79.2(87.12)	158.4(166.32)	316.8(348.48)	554.4(570.24)	712.8(744.48)	
Max. discharge pressure	MPa		0.5					
	bar		5					
	psi		72.5					
Strokes (spm)*2		9.6~96			8.9~89			
Stroke length (mm)		8			15	16	21	
Connection (flange)	Discharge side		JIS10K25A		JIS10K25A	JIS10K40A		
	Suction side		JIS10K25A*3	JIS10K40A	JIS10K50A	JIS10K65A		
Motor	Power supply (V)/frequency (Hz)		3-phase, 200 V/50 Hz, 200 V/60 Hz, 220 V/60 Hz, totally enclosed fan-cooled outdoor type (vertical flange mounting)					
	Output (kW)		0.2	0.4	0.75	1.5		
	Rated current/ max. startup current (A)	200V/50Hz		1.34 / 6.1	2.3 / 10.2	3.5 / 23.0	6.9 / 56.0	
		200V/60Hz		1.12 / 5.5	2 / 9.07	3.2 / 20.0	6.1 / 44.0	
		220V/60Hz		1.17 / 6.0	2 / 9.98	3.1 / 22.0	5.9 / 51.0	
Number of poles (P)		4						
Wiring conduit connection aperture		G 3/4						
Operating temperature range	Ambient temperature		0 to 40°C					
	Transferrable temperature		PVC type : 0 to 40°C (freezing not allowed) / Stainless steel type : 0 to 60°C (freezing not allowed)					
Transferrable viscosity		Max. 20000mPa·s*4						
Pump paint color	Body		Acryl urethane resin paint (Munsell 10YR 7.5/14)					
	Motor		Acryl urethane resin paint (Munsell N5.5)					
Weight (kg)*5			69		135	166		

\*1 Conditions: room temperature, clean water, standard valve used, inverter frequency 60 Hz The maximum discharge volume changes depending on the transfer conditions. Values in parentheses ( ) are the maximum discharge volume at a discharge pressure of 0.2 MPa.

\*2 When TACMINA-specified inverter is used    \*3 In the case of High-Viscosity type (FV□) is JIS10K40A.

\*4 It may change depending on the liquid property/transfer conditions of the pumping liquid. Contact your dealer or Tacmina.

\*5 In the case of a APL□-STST-FWS (stainless steel type). For details on other models, contact TACMINA.

External Dimensions

APL-5/10-STST-FWS

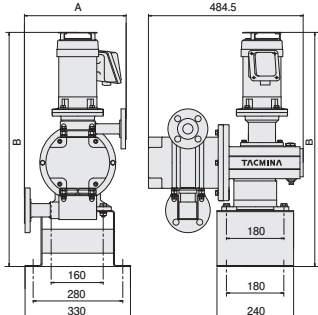

	A	B
APL-5-STST-FWS	283	732
APL-10-STST-FWS	308.5	733

APL-20-STST-FWS

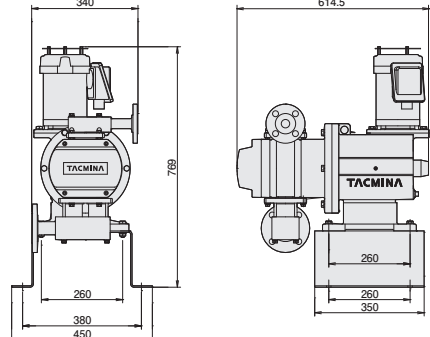

APL-35/50-STST-FWS

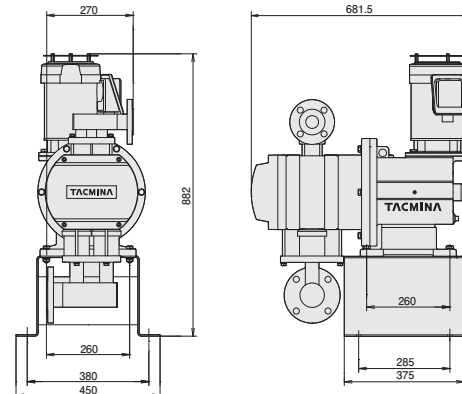

The above example performance specifications and external dimensions are for a standard model. These can be customized to suit customer specifications. For details, contact TACMINA.

**Performance curves**

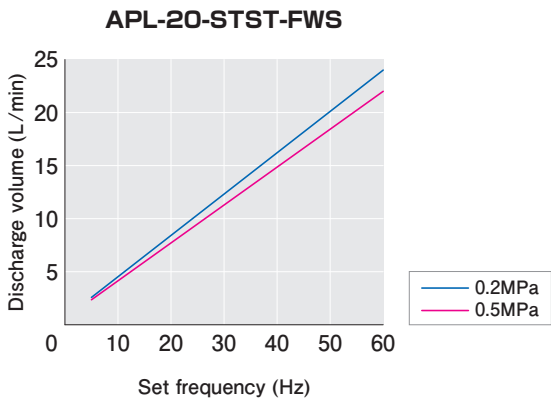
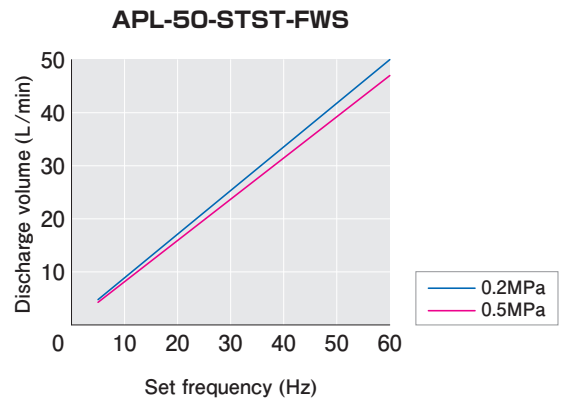
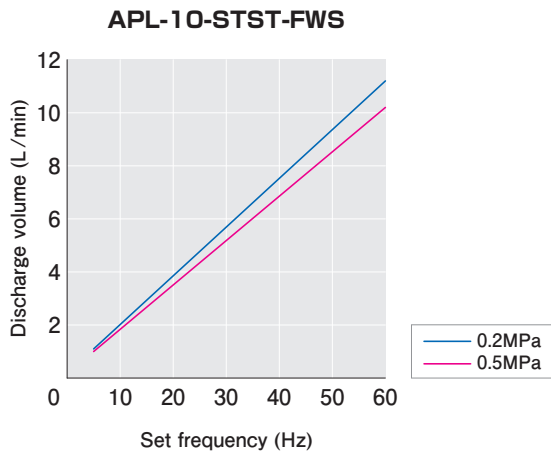
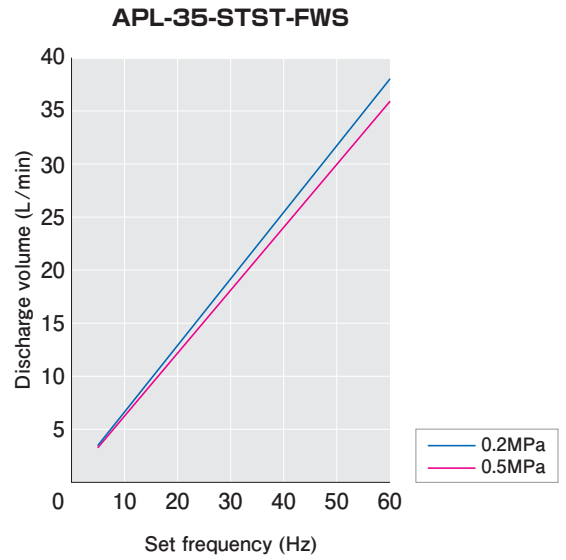
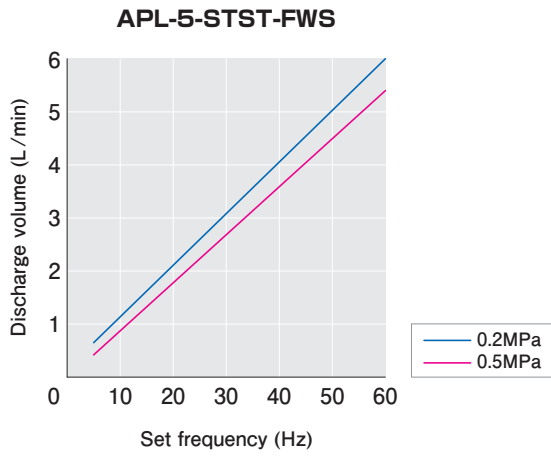

The example performance curves were obtained by measuring on test equipment at TACMINA under the following conditions.

Performance may differ slightly depending on the properties of the transferred liquid, operating conditions and product differences.

Measure the discharge volume under actual operating conditions, and set the frequency according to the performance curve that is obtained.

● Conditions : Clean water, room temperature

We hope that the following example is useful in sufficiently demonstrating the performance (metering characteristics, discharge accuracy, etc.) of metering transfer pumps and in preventing pump accidents or trouble.

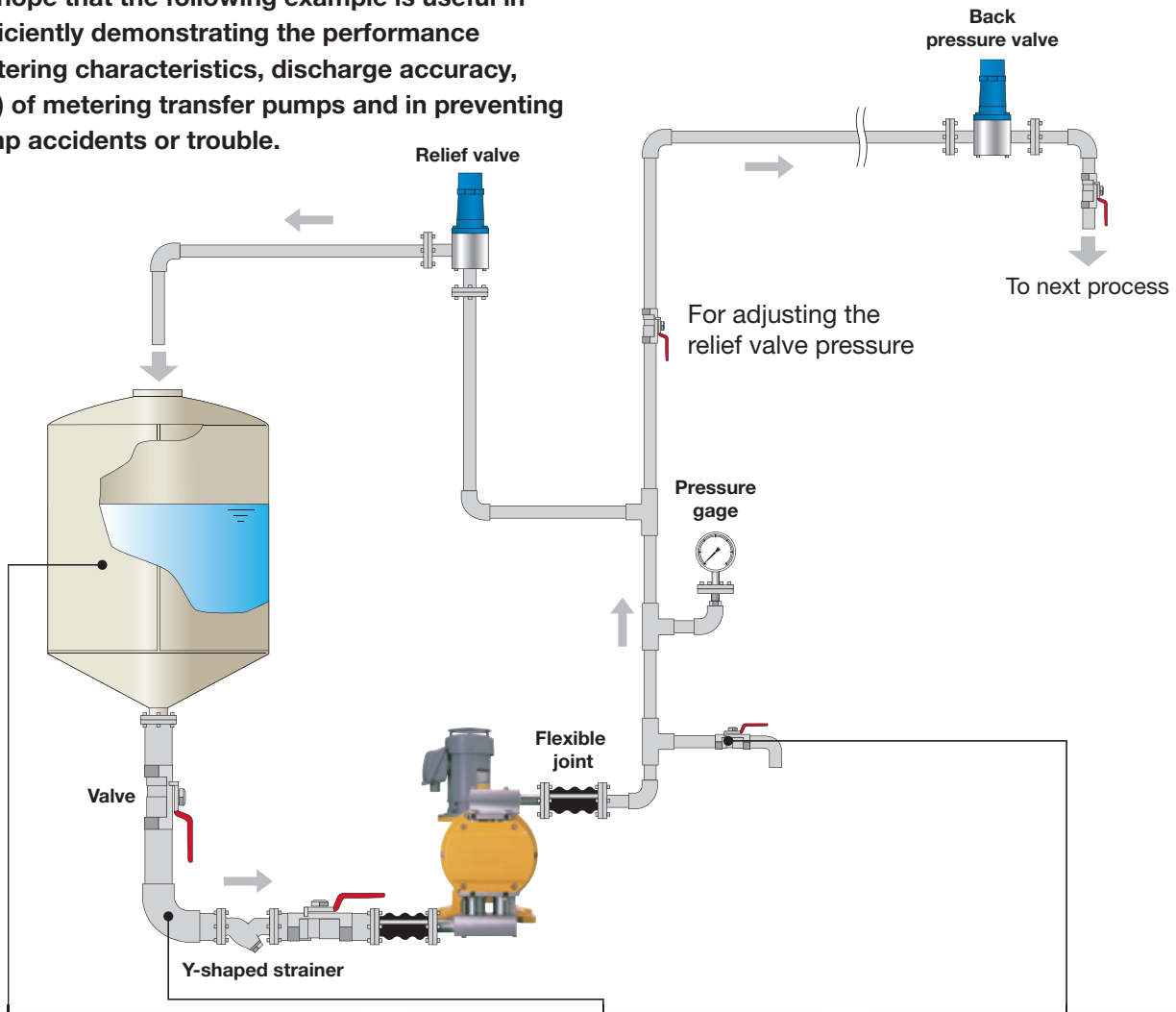

- Locate the tank at a position higher than the pump.

- Make the suction-side piping as large and simple as possible and use pressure booster piping. Use a charge tank or suction damper when only the suction side is to be extended for long distance.
- If necessary, provide air release piping on the suction side. (for example, when transferring liquids such as sodium hypochlorite that are likely to generate gas)

- Providing a valve for releasing air or releasing chemicals in the piping comes in very handy when performing maintenance.

- For the discharge-side and suction-side piping, choose piping having the same diameter as the pump aperture or larger to prevent piping accidents.

### Unacceptable Piping Examples

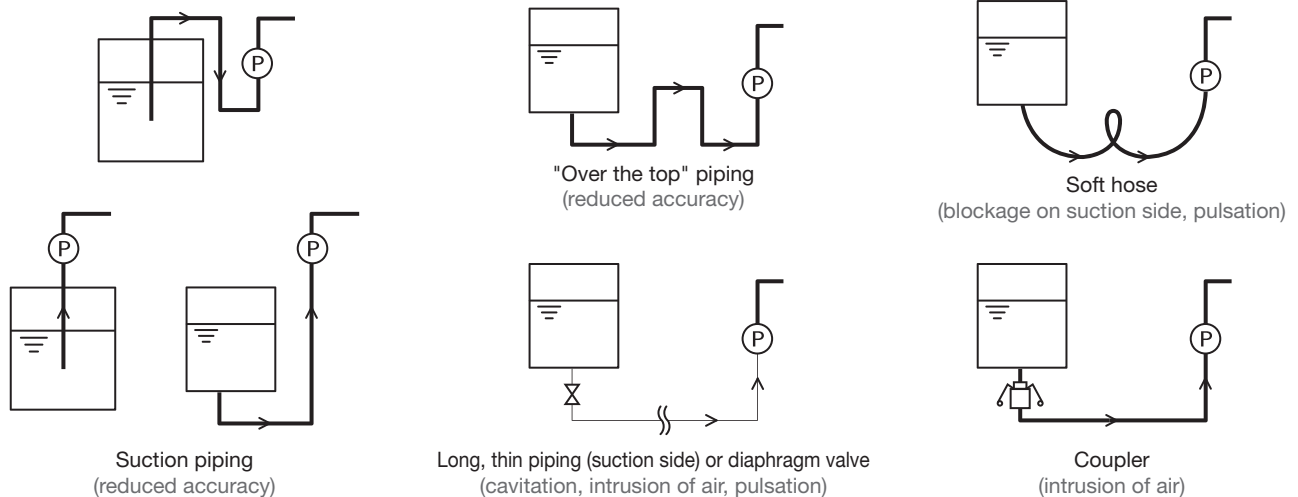

### Relief valve



- This relief valve automatically releases excess pressure that builds up in the discharge-side piping of the pump to prevent unexpected accidents.
- \* Install the relief valve near the pump on the discharge-side piping.
- \* Note that the relief valve will no longer be able to operate correctly if dirt builds up on the seal section.

### Back pressure valve



- This valve prevents overfeeding<sup>1</sup> and siphoning<sup>2</sup> phenomena.
  - Provide the back pressure valve near the injection point on the discharge-side piping.
- <sup>1</sup> Phenomenon where the momentum (inertia) of the push process in a flow having pulsation causes discharge to continue even in the stroke in which the pump is not discharging
- <sup>2</sup> Phenomenon where chemicals are sucked out naturally and continue to flow even with pump operation stopped as the tip of the pump's discharge-piping is located lower than the level of the liquid in the suction-side tank
- \* Note that the back pressure valve will no longer be able to operate correctly if dirt builds up inside the valve.

### Pressure gage



- Use this device to adjust the back pressure valve and relief valve.

### Valves



- When expensive liquids or dangerous chemicals are to be transferred, provide valves at appropriate locations to prevent chemical leakage to the outside during maintenance, for example.

### Y-shaped strainer



- Provide this strainer on the suction side to prevent the entry of dirt and other foreign matter.

### Flexible joint



- Use flexible joints to prevent piping loads or other loads from being placed on the pump.

### Refiner



- If you require higher precision performance, we recommend installing a refiner.

### Pulse Counter



- Use of the pulse counter allows you to calculate the approximate discharge volume, for example, the number of shots output by the pump per minute.
- It is also handy for batch injection and for checking the pump's running status.

Product designs and specifications are subject to change without notice for product improvement.

# TACMINA CORPORATION

**Head Office:**  
2-2-14 Awajimachi, Chuo-ku, Osaka 541-0047 Japan  
Tel.+81(0)6-6208-3974 Fax.+81(0)6-6208-3978  
URL <http://www.tacmina.com>  
E-mail [trade@tacmina.com](mailto:trade@tacmina.com)

EC-040(15)--
2017/5/S--



JQA-A-1274  
JQA-EMULSIF Production Department